

INTRODUCED BY:  
COUNCILOR WELDON



ORDINANCE NO. 2007-XX

A BILL TO BE ENTITLED

**AN ORDINANCE OF THE CITY OF NEPTUNE BEACH, FLORIDA ADDING ARTICLE III, RESIDENTIAL OUTDOOR LIGHTING REGULATIONS, SECTION 28-6 PURPOSE, SECTION 28-7 DEFINITIONS, SECTION 28-8 APPLICABILITY, SECTION 28-9 EXEMPTIONS, SECTION 28-10 GENERAL STANDARDS, SECTION 28-11 FURTHER RESTRICTIONS, SECTION 28-12 PENALTIES FOR VIOLATIONS, SECTION 28-13 SEVERABILITY, AND PROVIDING AN EFFECTIVE DATE.**

Whereas, the City Council of the City of Neptune Beach, Florida has determined that it is necessary to regulate residential lighting within the city:

Now, **Therefore**, be it ordained by the City Council of Neptune Beach, Florida:

Article III, Residential Outdoor Lighting Regulations, Section 28-6 to Section 28-13, Code of the City of Neptune Beach is hereby added as follows:

**Section 28-6: Purpose**

The purpose of the outdoor lighting ordinance on private property is to regulate residential outdoor lighting in order to reduce or prevent light pollution. This means to the extent reasonably possible the reduction or prevention of glare and light trespass, the conservation of energy, and promotion of safety and security. This article will ensure aesthetically appropriate residential outdoor lighting in keeping with the character of Neptune Beach.

**Section 28-7: Definitions**

As used in this article:

ACCENT LIGHTING: Any directional lighting which emphasizes a particular object or draws attention to a particular area.

DISABLING GLARE: Lighting that impairs visibility and creates a potentially hazardous situation for either pedestrians or motorists.

GLARE: The brightness of a light source that causes eye discomfort.

LAMP OR BULB: The light producing source installed in the socket portion of a luminaire.

LIGHT POLLUTION: General sky glow caused by the scattering of artificial light in the atmosphere and resulting in decreased ability to see the natural night sky.

LIGHT TRESPASS: Light emitted by a luminaire that shines beyond the property on which the luminaire is installed.

LUMINAIRE OR FIXTURE: A complete lighting unit including the lamps or bulbs, together with the parts required to distribute the light, to position and protect the lamps, and to connect the lamps to the power supply.

NUISANCE GLARE: Light that creates an annoyance or aggravation but does not create a potentially hazardous situation resulting from stray light from poorly shielded, aimed, placed, applied or maintained light sources.

SHIELDING: No light rays are emitted by a fixture above the horizontal plane running through the lowest point of the fixture where light is emitted.

SPOTLIGHT OR FLOODLIGHT: Any lamp that incorporates a reflector or a refractor to concentrate the light output into a directed beam in a particular direction.

### **Section 28-8: Applicability**

A. All residential outdoor lighting fixtures installed on private property shall comply with this ordinance and Division 3 Beachfront Lighting to Protect Marine Turtles in Article VII Coastal Construction Code. This article does not apply to interior lighting. However, overly bright inside light emitted outdoors from any structure will be subject to control by this article if it is determined by the code enforcement officer that it creates a "nuisance glare" or a "disabling glare" as defined by this article.

B. This ordinance may be enforced on the basis of a formal complaint filed in writing with the building department. All violations of this article shall be referred to the code enforcement board for disposition.

E. In the event of a conflict with any other section of this article, the more stringent requirement shall apply.

F. All governmental agencies, federal, state or county, including their security facilities, which operate within the city limits of Neptune Beach, should experience no difficulty meeting the requirements of this article and are encouraged by the city to comply with its provisions.

### **Section 28-9: Exemptions**

The following are exempt from the provisions of this article:

- A. Traffic control signals and devices.
- B. Streetlights installed prior to the effective date hereof.
- C. Temporary emergency lighting (i.e., fire, police, repair workers).
- D. Moving vehicle lights.
- E. Navigation lights (i.e. radio/television towers, water towers).
- F. Lighted signs that conform to the city's sign ordinance.
- G. Seasonal decorations with individual lights in place no longer than sixty (60) days.
- H. Sports field outdoor lighting (i.e., ball fields, football, soccer, ice rink, etc.).
- I. Other special situations approved by the city for temporary or periodic events (i.e., revivals, fairs, carnivals, festivals).
- J. Covered porch lighting on single-family or multi-family homes provided that each outdoor light fixture does not exceed 150 watts (2,220 lumens output).
- K. Security lighting that use motion detector switches that keep lights off except when approached and that switch lights on for the minimal duration possible that are used expressly for safety or security.

### **Section 28-10: General Standards**

The following general standards shall apply to all residential outdoor lighting, which is not exempted above:

- A. Outdoor lighting must be hooded, shielded, and/or aimed downward. Examples of acceptable and unacceptable light pollution control shielding and hooding is shown in tables 1-2 of this article.
- B. The hood or shield must mask the direct horizontal surface of the light source. The light must be aimed to ensure that the illumination is only pointing downward onto the ground surface, with no escaping light permitted to contribute to sky glow by shining upward into the sky.

C. Any bright light shining onto adjacent property or streets which would result in a nuisance glare or a disabling glare shall not be permitted. Light trespass beyond property boundaries or above the horizontal plane shall be considered noncompliant.

D. Existing fixtures may be adapted to comply with this chapter by adding a properly designed hood or shield, or by pointing any upward mounted, shielded fixture downward onto the ground surface.

E. All outdoor lighting fixtures shall be designed, installed, located and maintained such that nuisance glare onto adjacent properties or streets shall be minimized and all direct illumination kept within the boundaries of the fixture owner's property.

F. This article may be enforced on the basis of a formal complaint filed in writing with the building department.

G. Accent lighting, shall be directed downward onto the building or object and not toward the sky or onto adjacent properties. Direct light emissions shall not be visible above the roofline or beyond the building edge.

H. Spotighting on landscaping and foliage shall be limited to 150 watts (2,220 lumens output). The lamp shall be shielded and not create disabling or nuisance glare.

#### **Section 28-11: Further Restrictions**

The city reserves the right to further restrict outdoor lighting, including, but not limited to, searchlights for special events, laser lights, pole height, and level of illumination, when it is deemed to be in the best public interest in keeping with the stated purpose of this article.

#### **Section 28-12: Penalties for Violation**

A. Any violation of the provisions of this article shall be brought before the Code Enforcement Board for disposition

B. Each twenty four (24) hour period during any portion of which any violation of this chapter is committed or continued to exist shall constitute a separate offense.

#### **Section 29-13: Severability**

The provisions of this article are severable and if any paragraph, section, subsection, or part of this article is held to be invalid, unenforceable, unconstitutional, or inapplicable to any person or circumstance, such illegality, invalidity, unconstitutionality, or inapplicability shall not affect or impair the remainder of this article.

TABLE 1: WALL MOUNTED LIGHTS

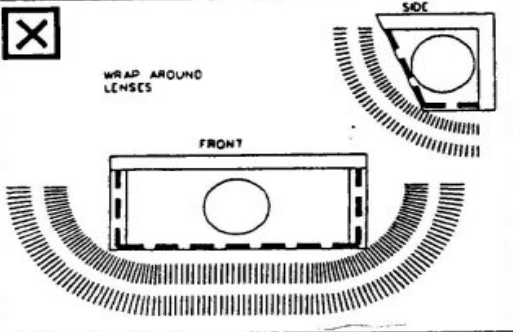
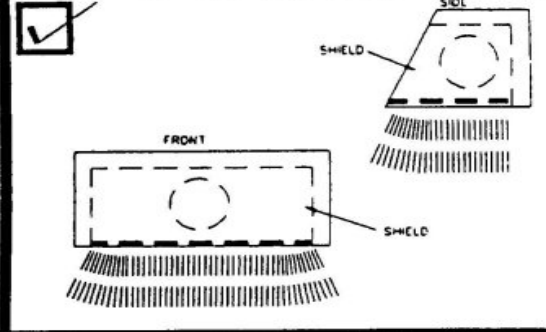
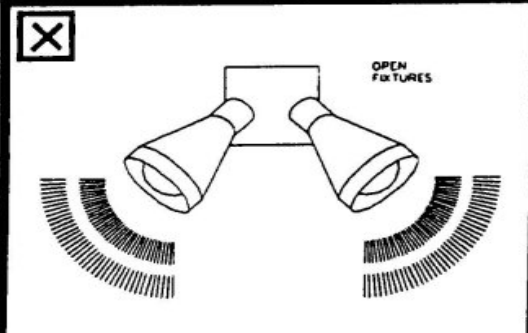
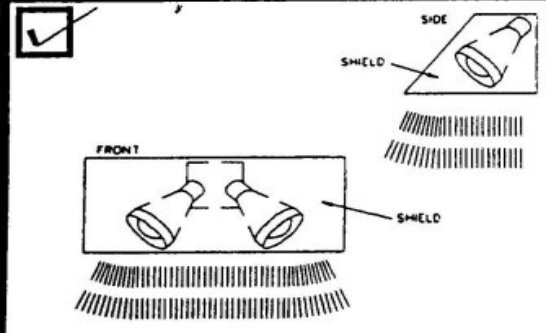
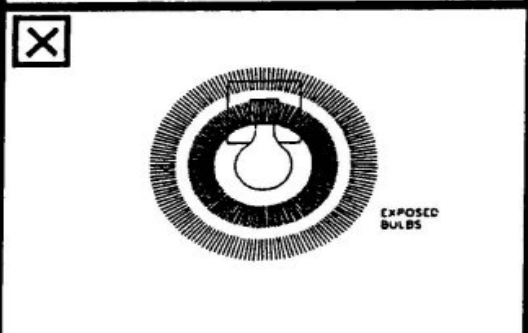
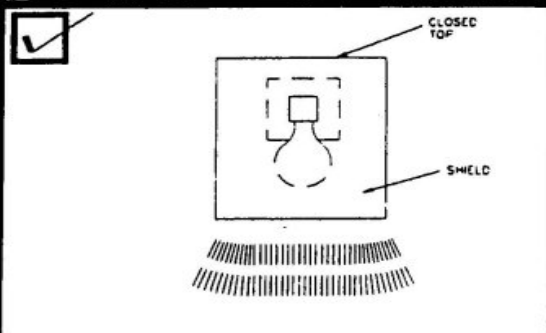
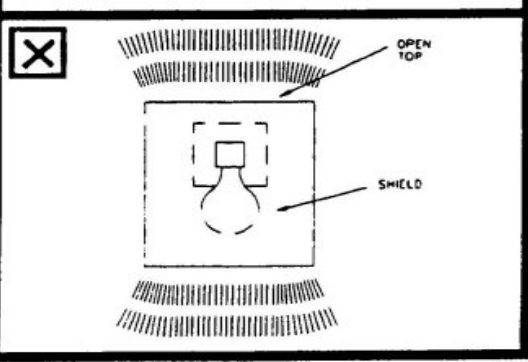
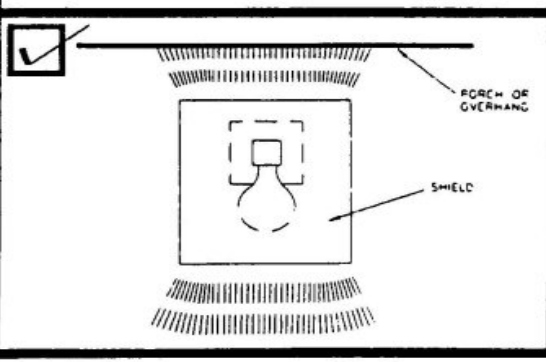
UNACCEPTABLE	ACCEPTABLE
<p data-bbox="282 373 342 422">✗</p> <p data-bbox="380 432 483 464">WRAP AROUND LENSES</p>  <p data-bbox="477 506 526 516">FRONT</p> <p data-bbox="672 365 704 375">SIDE</p>	<p data-bbox="812 373 872 422">✓</p>  <p data-bbox="954 506 1003 516">FRONT</p> <p data-bbox="1224 365 1256 375">SIDE</p> <p data-bbox="1110 407 1159 417">SHIELD</p> <p data-bbox="1175 585 1224 596">SHIELD</p>
<p data-bbox="282 709 342 758">✗</p> <p data-bbox="639 768 704 779">OPEN FIXTURES</p> 	<p data-bbox="812 709 872 758">✓</p>  <p data-bbox="883 848 932 858">FRONT</p> <p data-bbox="1208 722 1240 732">SIDE</p> <p data-bbox="1127 753 1175 764">SHIELD</p> <p data-bbox="1192 911 1240 921">SHIELD</p>
<p data-bbox="282 1045 342 1094">✗</p>  <p data-bbox="639 1247 704 1278">EXPOSED BULBS</p>	<p data-bbox="812 1045 872 1094">✓</p>  <p data-bbox="1208 1058 1273 1068">CLOSED TOP</p> <p data-bbox="1224 1205 1273 1215">SHIELD</p>
<p data-bbox="282 1381 342 1430">✗</p>  <p data-bbox="656 1415 704 1425">OPEN TOP</p> <p data-bbox="639 1562 688 1572">SHIELD</p>	<p data-bbox="812 1381 872 1430">✓</p>  <p data-bbox="1240 1457 1305 1488">PORCH OR OVERHANG</p> <p data-bbox="1224 1562 1273 1572">SHIELD</p>

The angle of light deflection from hoods or shields is to be no more than 45 degrees perpendicular through the light source (bulb or tube).

TABLE 2: STREET AND LOT LIGHT CUT OFF AT PROPERTY LINE

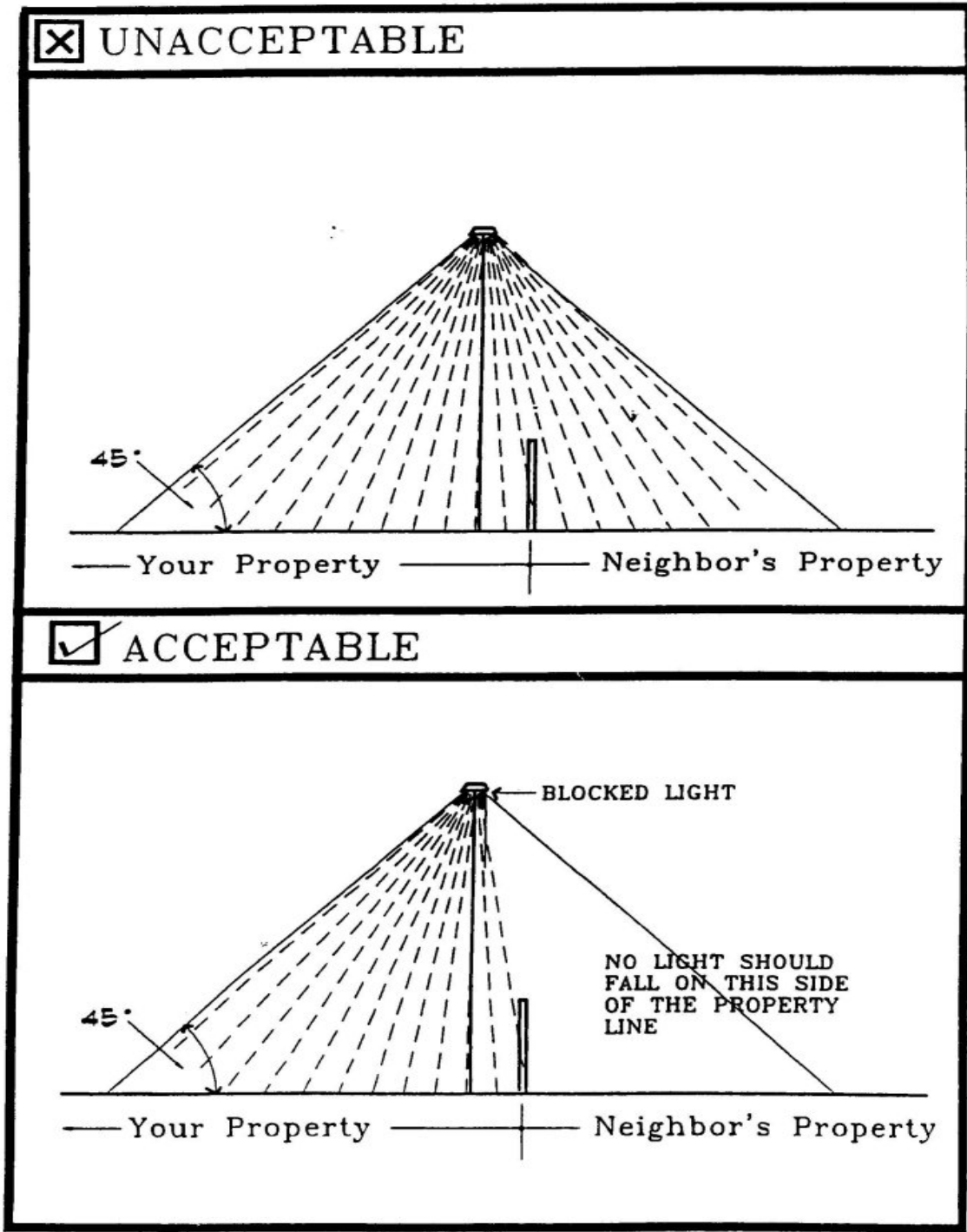

**Section 2.** The Ordinance shall become effective immediately upon its final passage and adoption by the City Council.

**VOTE RESULTS OF FIRST READING:**

Mayor Richard A. Brown.  
Vice Mayor Harriet Pruette  
Councilor Fred Lee  
Councilor Eric Pardee  
Councilor John Weldon

Passed on First Reading this \_\_\_\_ day of \_\_\_\_\_, 2007.

**VOTE RESULTS OF SECOND AND FINAL READING:**

Mayor Richard A. Brown  
Vice Mayor Harriet Pruette  
Councilor Fred Lee  
Councilor Eric Pardee  
Councilor John Weldon

Passed on Second and Final Reading this \_\_\_\_ day of \_\_\_\_\_, 2007.

---

Richard A. Brown  
Mayor

ATTEST:

---

Lisa Volpe, CMC  
City Clerk

Approved as to form and correctness:

---

Christopher A. White  
City Attorney